

SHDSL LAN EXTENDER

Focus g.shdsl.bis H301A

User Manual

Rev. 1.02

Web site : <http://www.elitel.pl>

1. Introductions

The STU-LAN H301A, an SHDSL (Single-pair High-bit-rate Digital Subscriber Line) LAN Extender, provides a broadband full duplex transmission with bandwidth up to 5.696 Mbps over a pair of copper line for point-to-point LAN connectivity between two Ethernet networks. The distances can reach respectively up to 7,000 feet (about 2.1 Km) and 10,000 feet (about 3 Km) at the rate of 5.696 Mbps and 4.608 Mbps for a pair of 24AWG (0.5 mm) copper wire, and could reach even around 27,500 feet (about 8.2 Km) at 192Kbps. With its rate adaptive features, H301A may provide data rates from 4.608 Mbps to 256 Kbps on different transmission distance. Users can also select a fixed data rate for the copper line ranging from 64 Kbps to 5.696 Mbps. The H301A provides a craft port for user to configure the settings and to monitor the connection status.

The H301A conforms to the ITU-T Rec. G.991.2 to meet G.shdsl.bis network requirements. Each STU-LAN H301A can be configured into either STU-C for central side or STU-R for remote side. A pair of STU-LAN H301A offers a cost effective symmetrical broadband solution for bandwidth-hungry applications such as LAN-to-LAN connectivity, Internet Access and VoIP applications over two twisted pairs.

2. Application Notes

1) Ethernet To Ethernet Bridge Extension

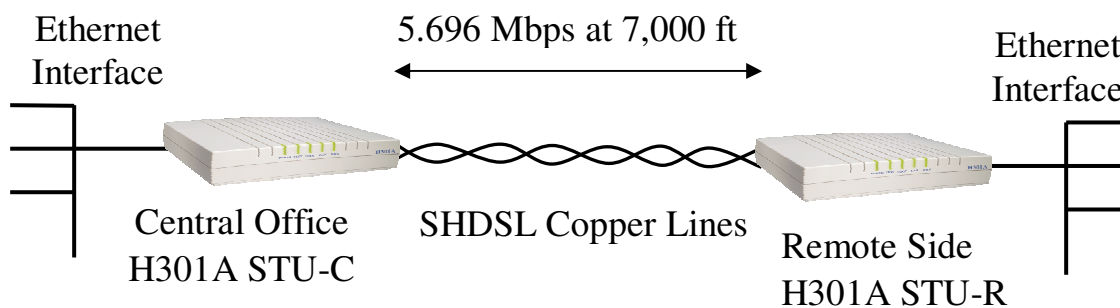

3. Features

- ITU-T Rec. G.991.2 G.shdsl.bis Compliance
- SHDSL Trellis Coded Pulse Amplitude Modulation (TCPAM) Line Code
- Fixed Data Rate Selection from 5696 Kbps to 64 Kbps for SHDSL line
- Adaptive Data Rate from 4608 Kbps to 192 Kbps for SHDSL line
- Maximum Transmission Distance: 22,500 ft over 26AWG twisted pair
- Noise Margin $\geq n$ dB($n=1\sim5$) is guaranteed for fixed rate and adaptive rate modes.
- STU-R will follow STU-C's speed for 192Kbps~2304Kbps in fixed rate mode.
- RJ-48 Connector for SHDSL line connections
- RJ-45 Connectors for 10/100 BaseT Ethernet Switch ports
- Ethernet Auto-Negotiation for 10/100 BaseT
- Ethernet Auto-MDIX for Auto Tx/Rx Swap
- Craft Port for Network Management Configurations
- 5 LED status indicators
- Power feedings: 100/220VAC to 12VDC Power Adaptor

4. Packing Contents

Inside the package you should find:

- (1) One STU-LAN H301A unit with dimension of 150x135x30 (mm)
- (2) One power cord
- (3) One DB-9 Console Cable
- (4) One User's Manual (Compact Disk)

Please check if the packing is damaged before unpacking or any component is missing. If so, please contact your dealer immediately for replacement.

5. Installation Procedures

Step 1 : Connect SHDSL Line to DSL RJ48 connector on H301A back panel

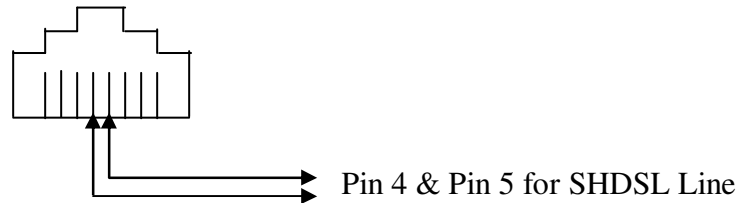

RJ-48 Connector Pin Assignment for SHDSL Line Interface

Step 2 : Connect Ethernet to RJ-45 Port with CAT 5 LAN cable

Step 3 : Connect the power adaptor to the H301A 12VDC outlet

Step 4 : Turn on the power. Set one H301A as STU-C from Craft port, and the other H301A as STU-R

Step 5 : Set the desired Data Rate for SHDSL connection from Craft port. Note that both H301A must set the same data rate settings.

Step 6 : Both units of H301A will automatically connect with each other.

Turn on the power, and STU-LAN H301A will then execute self-test routines. There will be 2 or more handshaking cycles when adaptive rate is selected. The system will automatically adapt to maximum rate according to the loop distances. The maximum rate is 5696 Kbps for 1-pair SHDSL line.

6. Front Panel LED Indicators

6.1 LED Indicators

There are 5 LED indicators on the front panel of H301A displaying the current status. These LED indicators are described as following.

POWER : “Green On” shows H301A power supply is normal.

TEST : H301A is self testing after powered on.

LOOP : “Green Flash” shows SHDSL connection is in progress.
: “Green On” shows SHDSL loop connects successfully.

LAN : “Green On” shows LAN port is in connection.
: “Green Flash” shows data activity on LAN port.

100M : “Green On” shows LAN Ethernet connection is at 100Mbps.

7. Craft Port Control

The STU-LAN H301A provides an RS232C craft port for user to monitor the OA&M status through a VT100 terminal. This section covers the operation procedures, settings and for all screen selections.

Connect the RS232 cable to the COM port of the computer as shown in the following diagram. Set the personal computer to VT100 or VT102 type through HyperTerminal. Press the <ESCAPE> key and the main menu will be shown on the screen of the terminal. The terminal operations can then start.

If the <ESCAPE> key is pressed and the screen of the terminal does not display, this may be due to the incorrect COM port setting. Choose the right COM port (COM1 or COM2) on the computer, and press the <ESCAPE> key again to make sure that the main menu appears on the terminal screen. Note that the COM port should be set as 9600 bps, none parity, 8 data bit, and 1 stop bit.

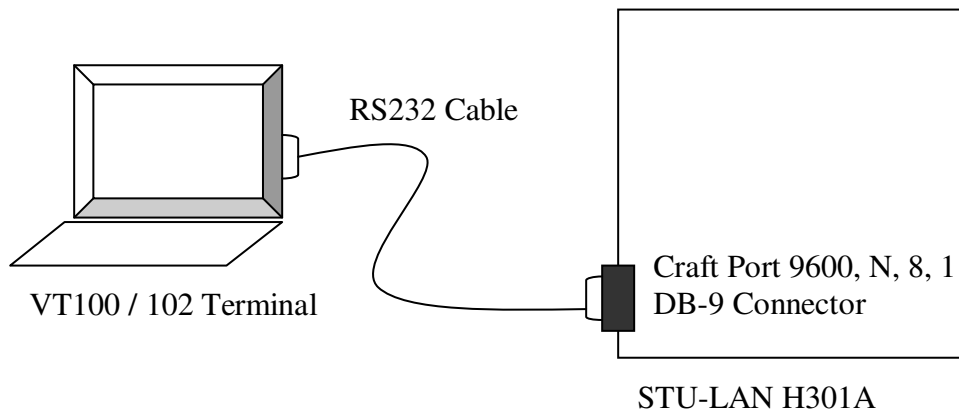

Figure 7-1: Connection for Craft Port with RS232 Terminal

7.1 Main Menu

Main Menu will display the connection status of the STU-LAN H301A unit and settings including two sections: Configuration, and Status. For details please refer to Table 7-1.

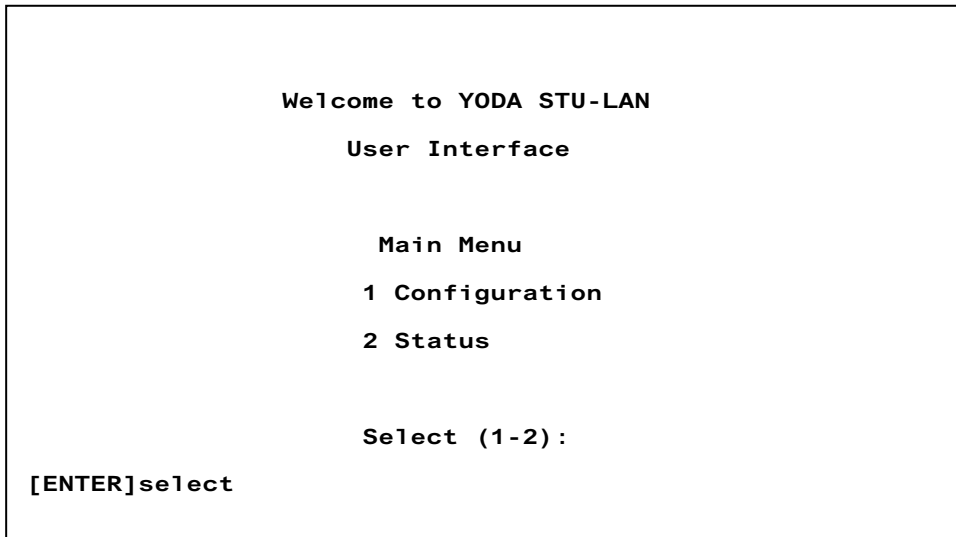

Table 7-1 Main Menu

The pull-down tree structure of the main menu is shown in Figure 7-2.

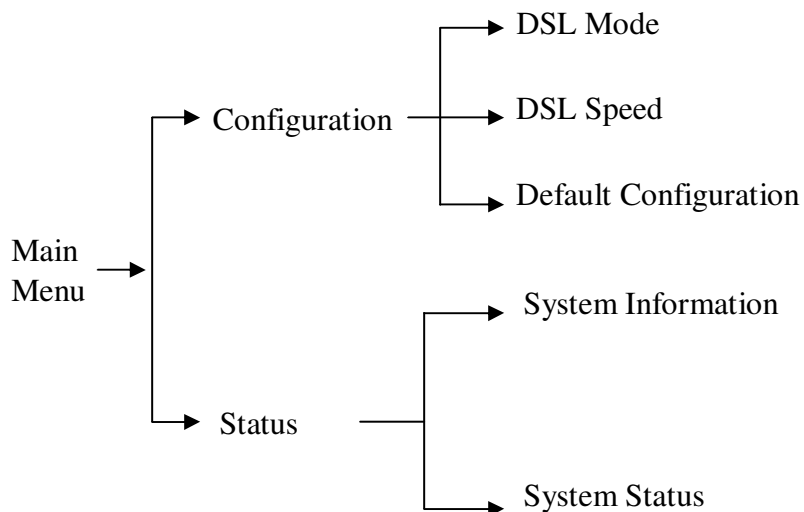

Figure 7-2: Pull-down Tree Structure of the main menu

7.2 Configuration Screen

Configuration screen will display the selections of connection for the H301A unit and the screen includes three selections: DSL Mode Settings, DSL Speed Settings, and Default Configuration.

For details please refer to Table 7-2.

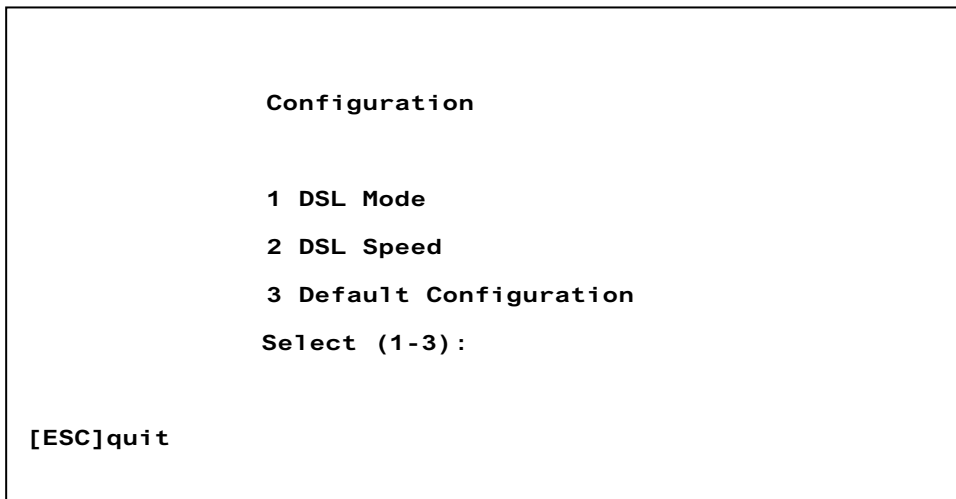

Table 7-2 Configuration screen

DSL Mode Settings:

DSL Mode		
CO/RT	PAIR	Minimum Noise Margin
-----	-----	-----
STU-C	1 Pair	NM=1 dB

[ARROW RIGHT][ARROW LEFT]type [SPACE]option
[ENTER]select [ESC]quit

Table 7-3: DSL Mode Settings screen

This screen provides DSL mode settings and user can update the settings from this screen. The initial values of DSL Mode settings are read from EEPROM.

CO/RT:

The item of CO/RT has 2 options: STU-C and STU-R. To establish a successful connection for two H301A units, it is necessary to set one unit to STU-C and the other unit to STU-R.

PAIR:

H301A supports 1-Pair SHDSL application. To establish a successful connection for two H301A units, it is necessary to set the two units to the same selection.

Minimum Noise Margin:

The item of Minimum Noise Margin has 6 options: NM=OFF, NM= 1dB, NM=2dB, NM=3 dB, NM=4 dB, or NM=5 dB. If user sets to NM= 1dB, then noise margin ≥ 1 dB is guaranteed for DSL connection. If user sets to NM=OFF, this function is disabled.

DSL Speed Settings:

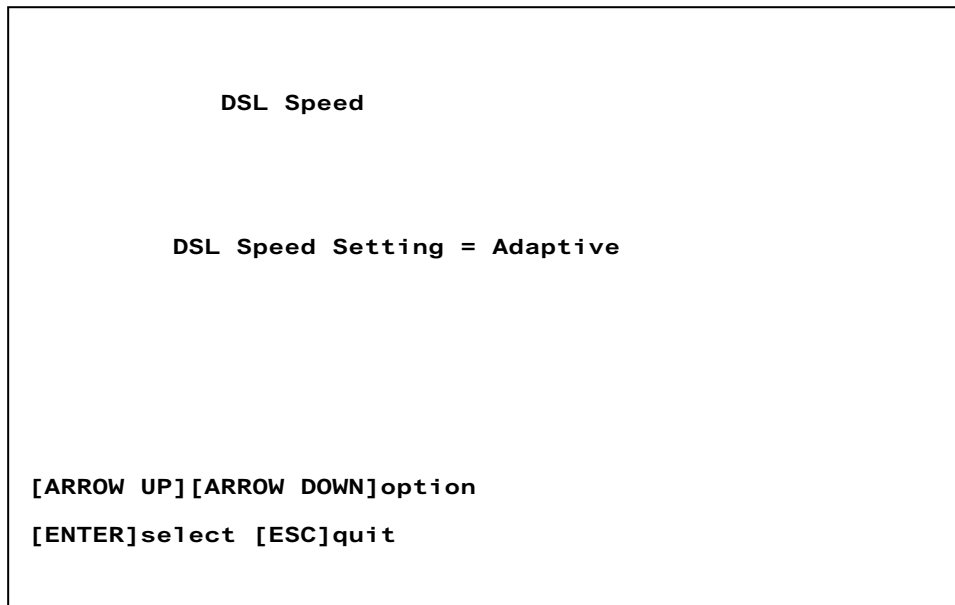

Table 7-4 DSL Speed Settings screen

This screen provides DSL Speed Settings and user can configure DSL speed to set the transmission rate.

For 1-pair setting in the DSL Mode menu, the options are as following;

64 kbps, 128 kbps, 192 kbps, 256 kbps, 384 kbps, 512 kbps, 768 kbps, 1152 kbps, 1536 kbps, 1544 kbps, 2048 kbps, 2304 kbps, 2560 kbps, 2816 kbps, 3072 kbps, 3328 kbps, 3584 kbps, 3840 kbps, 4096 kbps, 4352 kbps, 4608 kbps, 5120 kbps, 5376 kbps, 5696 kbps, and Adaptive speed.

The user must set both units of H301A to the same speed selection in order to establish a successful connection for 64 kbps, 128 kbps, 2560 kbps, 2816 kbps, 3072 kbps, 3328 kbps, 3584 kbps, 3840 kbps, 4096 kbps, 4352 kbps, 4608 kbps, 5120 kbps, 5376 kbps, 5696 kbps, and Adaptive speed.

For the rate speed options between 192 kbps and 2304 kbps, the STU-R H301A regardless its speed option will follow the speed of STU-C H301.

When setting for adaptive rate, 2 or more activation cycles are necessary. The system will automatically adapt to maximum speed according to the loop distances. The maximum speed for adaptive rate is 4608 kbps.

Default Configuration Setting:

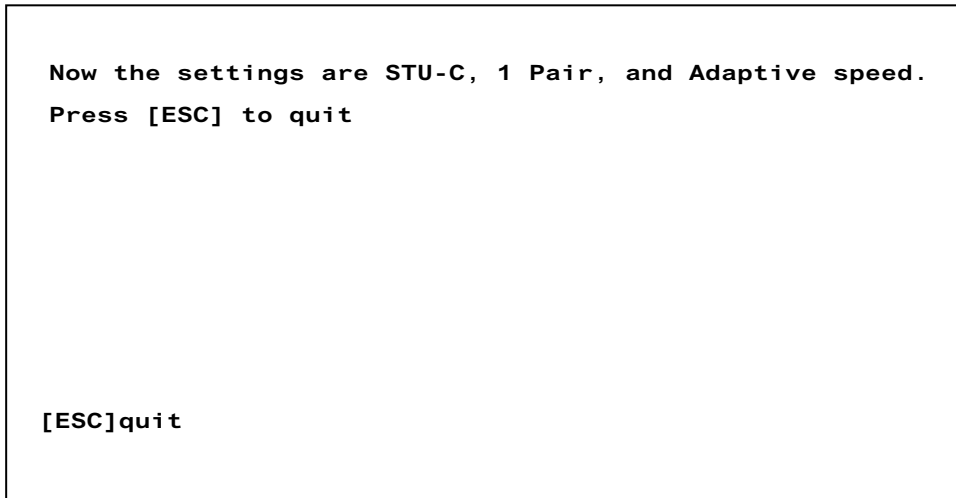

Table 7-5 Default Configuration Setting screen

When Default Configuration is selected, all the settings of H301A will go back to default settings. For the screen as shown in Table 7-5, it indicates setting is finished and press <ESC> key will be back to previous screen. The default settings of H301A are as following:

STU-C
1 Pair
Adaptive speed
NM=1 dB

7.3 Status Screen

The Status screen shows the connection status of H301A unit. The screen covers two selections: System Information and System Status. For details please refer to Table 7-6.

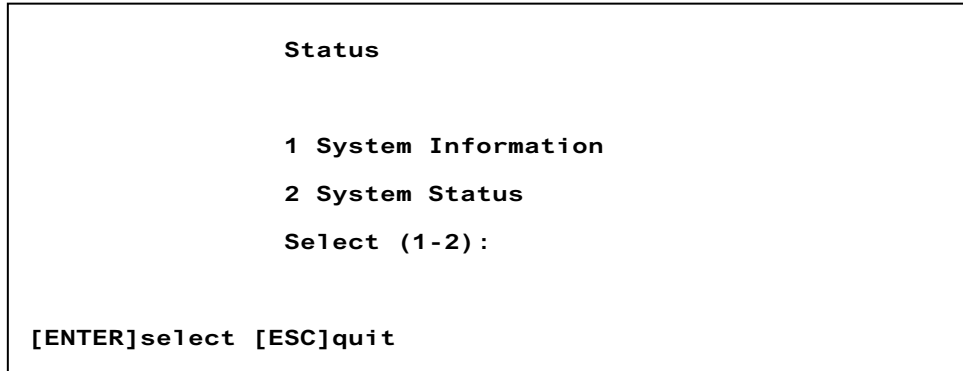

Table 7-6 Status screen

System Information:

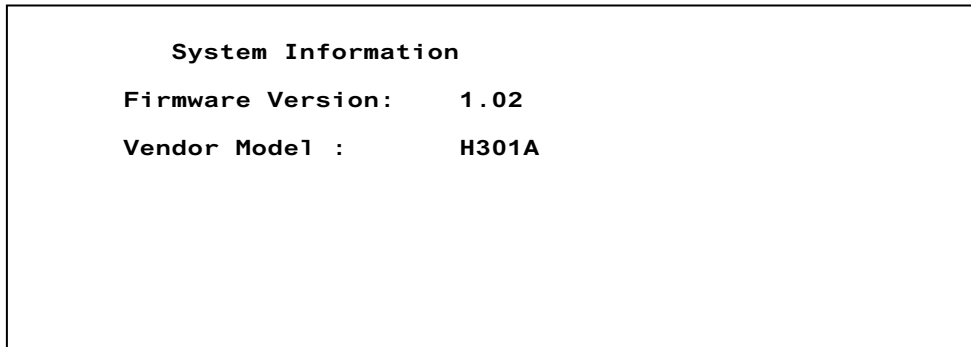

Table 7-7 System Information screen

Items list in the above screen are explained as follows:

Firmware Version:

Indicates the firmware version in this unit.

Vendor Model:

Indicates this device's vendor model name.

Vendor Information:

Indicates the vendor's web site information.

System Status screen:

System Status		
DSL mode:	STU-C	1 Pair NM=1 dB
Speed setting:	Adaptive	
Speed actual(kbps):	4608	
Link status of pair #1:	up	
Noise Margin of pair #1(dB):	08	
Line Attenuation of pair #1(dB):	22	
Activation state of pair #1:	16	

[ESC]quit

Table 7-8 System Status screen. The distance of this example is 6Kft and 26-AWG.

Items list in the above screen are explained as follows:

DSL mode:

Indicates the current DSL mode setting.

Speed setting:

Indicates the current DSL speed setting.

Speed actual (kbps):

Indicates the actual DSL speed in kilobit per second.

Link status of pair #1:

Indicates the DSL connection status (either up or down) for pair #1.

Noise Margin of pair #1(dB):

Indicates the Noise Margin in dB of pair #1.

Line Attenuation of pair #1(dB):

Indicates the Line Attenuation value in dB of pair #1. The maximum value is 43 dB when the DSL distance is 22500 ft, 26-AWG.

Activation state of pair #1(dB):

Indicates the DSL startup activation state of pair #1. The value starts from 05 and gradually reaches the final value 16. The value 16 is the DSL link up state value. The general activation state sequence is 05 → 20 → 10 → 12 → 16.